

Motorola PTP Ethernet Microwave Solution



Portfolio - Product Summary



	PTP 500	PTP 600	PTP 800
Applications	Challenging links of low to medium capacity	Challenging links of medium to high capacity	High capacity links, usually straightforward deployment scenarios
Max. Ethernet Throughput (full duplex)	Lite: 25Mbps Full: 50Mbps	Lite: 75Mbps Full: 150Mbps	10 to 368Mbit/s
Frequencies	5.4, 5.8GHz	2.5, 4.5, 4.9, 5.4, 5.8GHz	6, 7, 8, 11, 13, 15, 18, 23, 26, 28, 32, 38GHz
Spectrum	Unlicensed	Both	Licensed
Antennas	Integrated or Connectorised	Integrated or Connectorised	Direct or Remote Mount
RF Path	NLOS Capability Dynamic TDD	NLOS Capability Dynamic TDD	LOS only FDD

Extending the PTP Portfolio

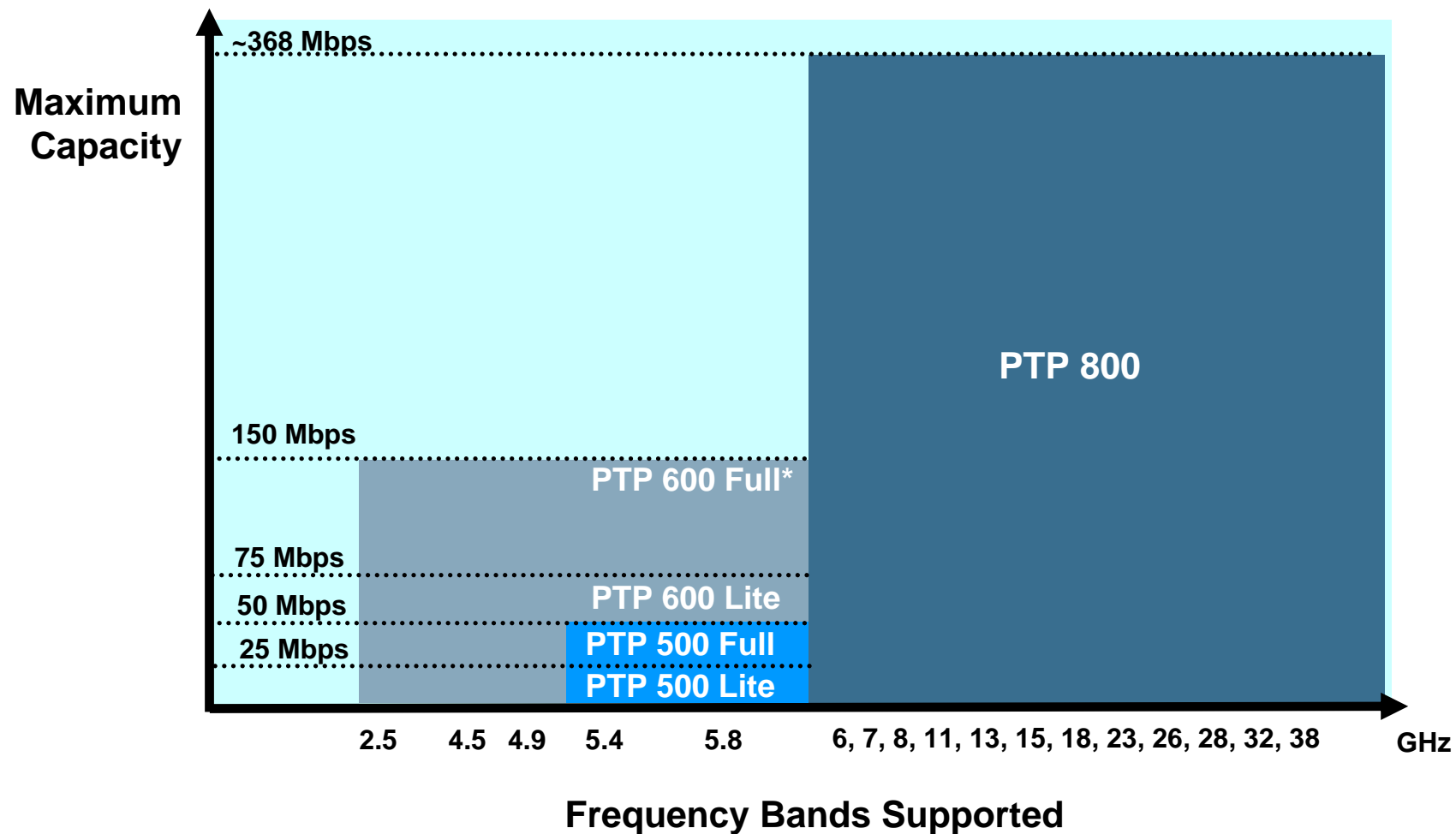

(Note: Throughputs always stated as Full Duplex in Licensed Microwave market)

PTP 500 Configuration Options



**PTP 500 Integrated
with dual built-in
antennas**



**PTP 500 Connectorised: high-gain
advantage of external antennas**



**Power Indoor Unit (PIDU Plus):
Power-over-Ethernet to outdoor units**

PTP 500 Specifications



PTP 500 SPECIFICATION TABLE	
Frequency bands	5.4GHz, 5.8GHz unlicensed
Speed	Up to 50Mbit/s full duplex (Dynamic TDD - 66% max in up/down)
Interfaces	10/100BaseT + 1 x T1/E1
Range	Up to 155 miles (line-of-sight)
Ethernet Frame Size	Baby Jumbo Frames - 2000 bytes
Latency	< 3ms
Channel sizes	5, 10, 15 MHz
Modulation	OFDM: BPSK – 64QAM, adaptive Modulation
Security	Optional 128/256 bit AES, FIPS-197
QoS	802.1p
Configuration options	Integrated, Connectorised, PIDU (Power over Ethernet)
Lightning protection	Built into ODU
Management	Remote web browser, SNMP

PTP 600 Configuration Options



**PTP 600 Integrated
with dual built-in
antennas**



**PTP 600 Connectorised:
high-gain advantage of
external antennas**



**Power Indoor Unit
(PIDU Plus):
Power-over-Ethernet
to outdoor units**



**Lightning
Protection Unit**

PTP 600 Specifications



PTP 600 SPECIFICATION TABLE	
Frequency bands	2.5GHz, 4.5GHz, 4.9GHz licensed; 5.4GHz, 5.8GHz unlicensed
Speed	Up to 150Mbit/s full duplex (Dynamic TDD – 75% max up/down)
Interfaces	10/100/1000BaseT + 2x E1/T1 (optional Fiber Gig-E)
Range	Up to 124 miles (line-of-sight)
Ethernet Frame Size	Baby Jumbo Frames - 2000 bytes
Latency	< 1ms
Channel sizes	5, 10, 15, 30MHz
Modulation	OFDM: BPSK – 256QAM, adaptive Modulation
Security	Optional 128/256 bit AES, FIPS-197
QoS	Enhanced 802.1p
Configuration options	Integrated, Connectorised, PIDU (Power over Ethernet)
Lightning protection	Available separately
Management	Remote web browser, SNMP

PTP500/600 Competitive Advantage

Unique features - works where competitors don't



- **Spectral Efficiency**
 - Maximum Throughput in Minimum Spectrum Capacity
 - 10 bps/Hz
- **Best in class Link budget**
 - Best in class link budget
 - 10 dB better than closest competitor
- **MIMO (Multiple Input Multiple Output)**
 - Vastly improve availability on NLOS and tough LOS links
 - Dual payload on clean LOS links
- **Intelligent DFS**
 - Real-time Spectrum Analyzer as standard
 - Tx and Rx frequency are independent, provide more channel combinations.
- **Space Diversity**
 - The only unlicensed radio support Spatial Diversity
- **TDD Synchronization**
 - Minimizes interference
 - Improves frequency re-use
- **Easy to Plan & Install**
 - PTP LINKPlanner

#1 Market Share in Unlicensed Diversifying into adjacent markets



Commercial / Enterprise
Petrochemical
Utility

WISP
Carrier

Government
Public Safety
Defence



PTP800 Introduction

Introducing the . . .



PTP 800

- 6 to 38 GHz licensed bands (available in a series of product releases)
- Configurable channel bandwidths from 7 MHz to 56 MHz
- Up to 368 Mbps user Ethernet throughput (full duplex)
- Low latency – to $< 115 \mu\text{s}$ @ 368 Mbps
- Fixed Modulation and Adaptive Coding and Modulation (ACM)
- In-band and out-of-band management
- FIPS-197 128/256-bit AES encryption (optional)

Components



PTP 800 ODU



PTP 800 CMU

- Split-mount architecture:
 - Outdoor unit (ODU)
 - Compact modem unit (CMU)
- Modem design:
 - Frequency and capacity independent
 - Small footprint (7.1" x 1.4" – 18.0 cm x 3.5 cm)
 - Rack or wall mount / easy installation
 - Indoor installation
- Operating temperatures -27° F to +131° F (-33° C to +55° C)
- 100/1000 Base T (RJ-45) – auto MDI/MDIX
- 1000 Base SX/LX option
- BNC connector at ODU for fast and easy link alignment

System Components



Antenna



ODU



CMU



IF Cable



Cable Assembly Kit



LPU Kit

Modem



Known as the Compact Modem Unit (CMU)

Modem Interfaces

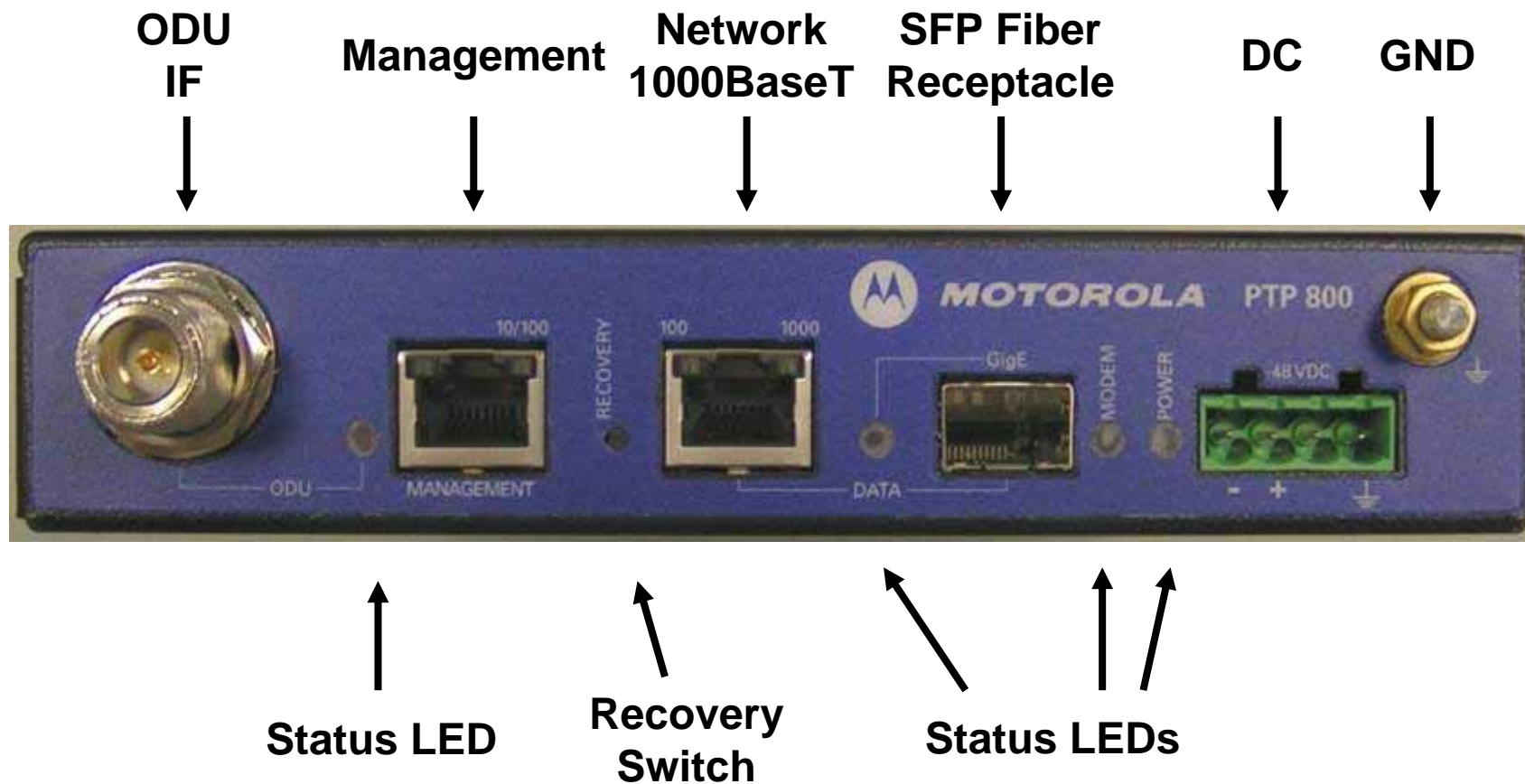

Exceptional Scalability



PTP 800 CMUs ship with 10 Mbps capacity cap

PTP 800 CMU Capacity Cap Upgrades

Single-Step Capacity Upgrades	Step-by-Step Capacity Upgrades
X ▶ 20 Mbps (per unit)	10 ▶ 20 Mbps (per unit)
X ▶ 30 Mbps (per unit)	20 ▶ 30 Mbps (per unit)
X ▶ 40 Mbps (per unit)	30 ▶ 40 Mbps (per unit)
X ▶ 50 Mbps (per unit)	40 ▶ 50 Mbps (per unit)
X ▶ 100 Mbps (per unit)	50 ▶ 100 Mbps (per unit)
X ▶ 150 Mbps (per unit)	100 ▶ 150 Mbps (per unit)
X ▶ 200 Mbps (per unit)	150 ▶ 200 Mbps (per unit)
X ▶ 300 Mbps (per unit)	200 ▶ 300 Mbps (per unit)
X ▶ Full Capacity (per unit)	300 ▶ Full Capacity (per unit)

Asymmetric capacity control

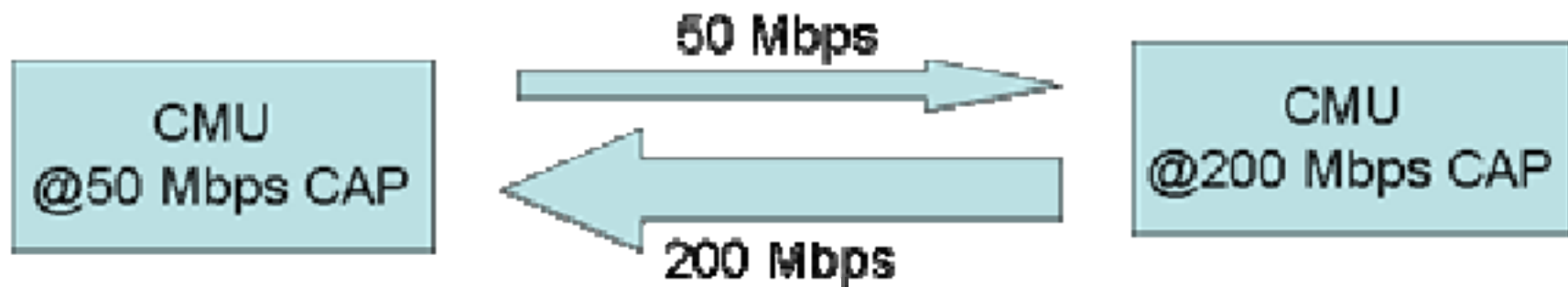

Example of 200 Mbps DL and 50 Mbps UL

What is PTP800 ACM?



- **“Errorless and Hitless” ACM**
 - “Hitless” means no suspension of traffic flow during switch
 - “Errorless” means no errors during switch
- **ACM is an link adaptation method that promises to raise the overall system capacity and improve the link availability.**

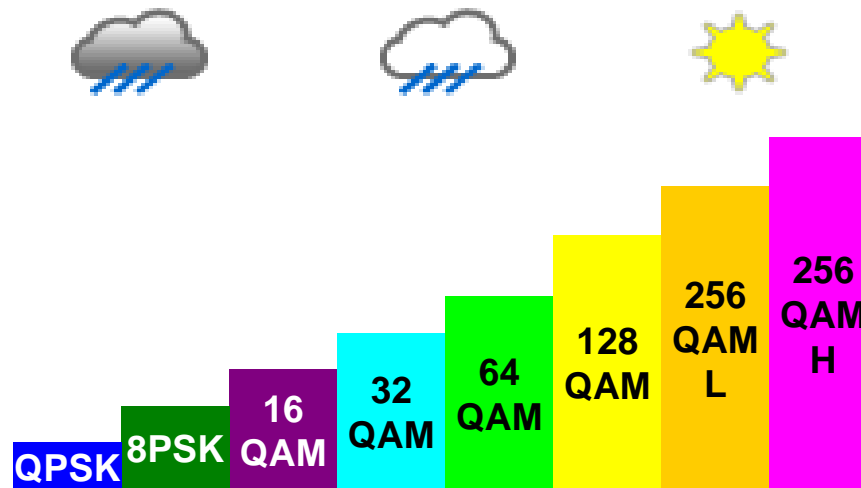

Motorola's Approach to ACM



- **With more than 5 years experience on deploy adaptive modulation, Motorola know to do ACM properly.**
 - Hitless and Errorless during modulation shift
 - Up to 8 level of ACM profile
 - Support QPSK, 8PSK, 16/32/64/128/256 QAM with different coding rate
 - Quick shifting
 - Can cope with up to 100 dB/sec fading change
 - Flexible control
 - Customer can define the Maximum and Minimum modulation mode
 - Easy setup
 - After initial setup, no further user intervention is required. The regulation rules are embedded into the link installation wizard. The customer does not need to worry about any violation of regulation rules when ACM is enabled.
 - Easy planning
 - PTP LINKPlanner supports both fixed mode and ACM mode; customer can easily design and compare the radio performance and make the choice with all necessary information.

How ACM Works?

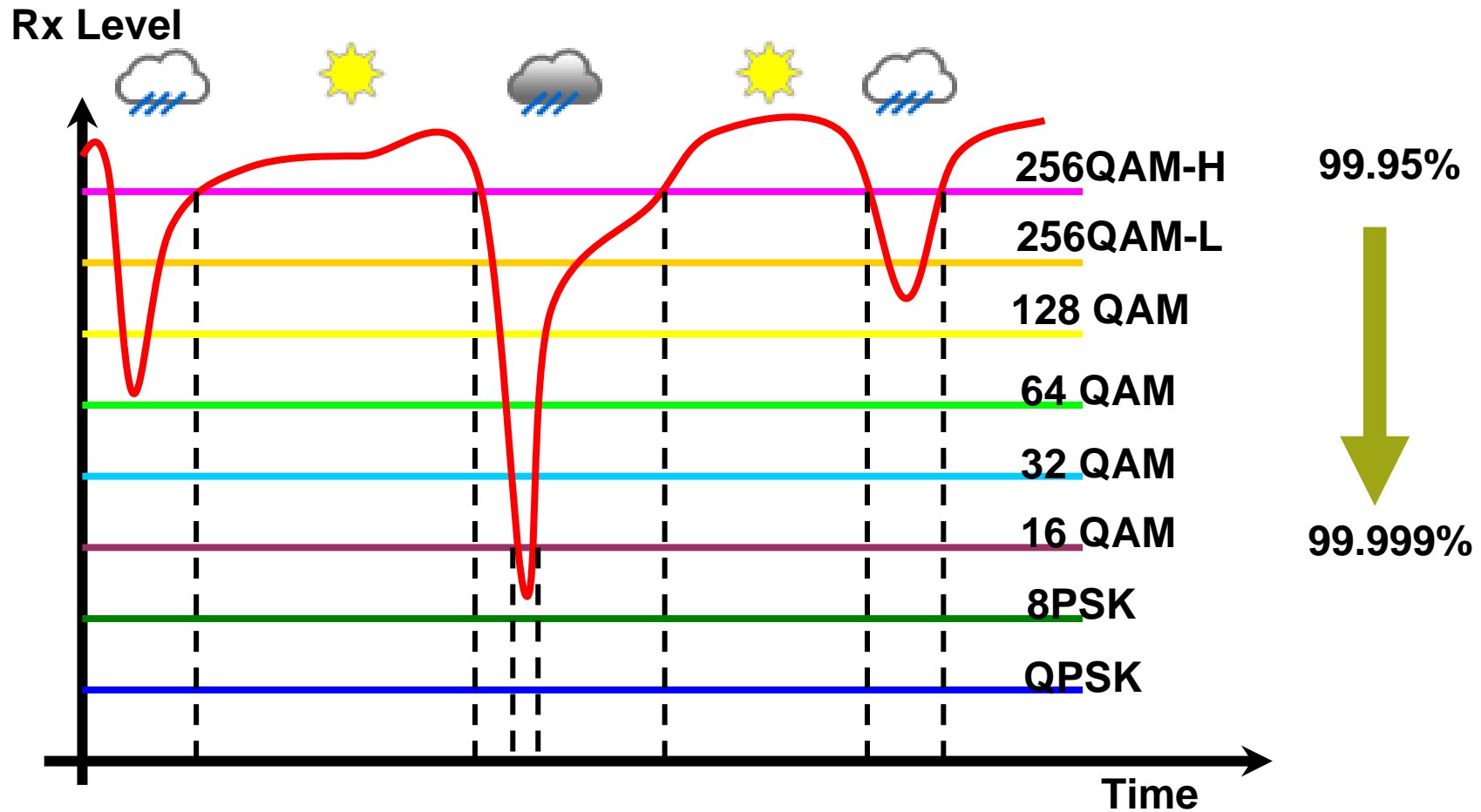

Benefits of ACM



Provide higher average link capacity.	<ul style="list-style-type: none">- Improved Spectrum efficiency by shifting to higher modulation, provide additional end-user capacity*.- In most of the operation time, link works on top rate mode.
Improved link availability	<ul style="list-style-type: none">- Extra fade margin by shifting to lower modulation
Continued transport, minimizes link outage	<ul style="list-style-type: none">- The consequence of a wireless link outage could cause several seconds due to TCP/IP timeout, re-route and recovery.
Graceful throughput change	<ul style="list-style-type: none">- QPSK to 256 QAM with 8 ACM profile levels
CAPEX and OPEX Savings	<ul style="list-style-type: none">- A standard feature of PTP 800, no additional cost- Easy to setup and no further intervention required- Easy design with PTP LINKPlanner- Reduce antenna size- Reach longer range

* up to the maximum provided by the user's capacity CAP

How to enable ACM

- using installation wizard



ETSI

Step 2: Enter details of the Radio License

Radio license data entry

Attributes	Value	Units
Radio License Identifier	<input type="text"/>	
Radio License Band	26 GHz	
Radio License Region	ETSI	
Radio License Channel Separation	56 MHz	
Radio License Modulation Selection	<input checked="" type="radio"/> Adaptive Modulation <input type="radio"/> Fixed Modulation	
Radio License Ref. Modulation	128QAM 0.82	
Radio License Max EIRP	90.0	dBm
Radio License Tx Freq	24997.000	MHz
Radio License Rx Freq	26005.000	MHz

<< Back

Next >>

Step 3: Enter wireless configuration

Wireless configuration data entry

Attributes	Value	Units
Maximum Transmit Power (Max 17.0, Min 7.0)	15.0	dBm
Max Mod Mode (Max 256QAM 0.91)	256QAM 0.80	
Min Mod Mode	QPSK 0.80	

<< Back

Next >>

FCC/IC

Step 2: Enter details of the Radio License

Radio license data entry

Attributes	Value	Units
Radio License Identifier	<input type="text"/>	
Radio License Band	23 GHz	
Radio License Region	FCC	
Radio License Bandwidth	50 MHz	
Radio License Modulation Selection	<input checked="" type="radio"/> Adaptive Modulation <input type="radio"/> Fixed Modulation	
Radio License Max Mod Mode	256QAM 0.83	
Radio License Min Mod Mode	QPSK 0.80	
Radio License Max EIRP	90.0	dBm
Radio License Tx Freq	21905.000	MHz
Radio License Rx Freq	23009.000	MHz

<< Back

Next >>

Step 3: Enter wireless configuration

Wireless configuration data entry

Attributes	Value	Units
Maximum Transmit Power (Max 15.0, Min 2.0)	15.0	dBm

<< Back

Next >>

Use cases of ACM



	Results Compared to Fixed Mode	Configuration
Setup 1	<ul style="list-style-type: none"> - Higher average link throughput - Keep the same link availability - No throughput reduction compare with fix mode 	<ul style="list-style-type: none"> - Keep “Min Mod mode” the same as fixed mode - Set “Max mod mode” to higher modulation
Setup 2	<ul style="list-style-type: none"> - Higher average link throughput - Minimize link outage with improved link availability. - During deep fade, link is up with lower capacity 	<ul style="list-style-type: none"> - Set “Min Mod mode” to lowest modulation - Set “Max mod mode” to top rate mode.
Setup 3	<ul style="list-style-type: none"> - Higher average link throughput - Keep the same link availability with lower capacity during deep fade. - Cost saving on antenna 	<ul style="list-style-type: none"> - Set “Min Mod mode” to lowest modulation - Set “Max mod mode” to top rate mode. - Reduce antenna size
Setup 4	<ul style="list-style-type: none"> - Higher average link throughput - Keep the same link availability with lower capacity during deep fade. - Reach longer range 	<ul style="list-style-type: none"> - Set “Min Mod mode” to lowest modulation - Set “Max mod mode” to top rate mode.

Fast Ethernet Shutdown



- The PTP 800 CMU will disconnects the Data and management Ethernet ports at each end of the wireless link within 50 ms, to alert the connected network equipment that one or both directions of the wireless link have been lost.
- Achieve the best traffic re-route time using this feature in a redundant layer 2 bridged network based on Rapid Spanning Tree Protocol (RSTP) or ITU-G 8032 (Ring protection protocol).

Quality of Service



- Support 802.1p/1Q
 - Eight traffic classes with strict scheduling
- Support 802.1ad (Q-in-Q)
- Layer 2 Control Protocol Frames (L2CP) classification
 - Provides separate classification of Ethernet frames that contain an IEEE 802.1 bridge protocol (including STP, RSTP, PAUSE), Generic Attribute Registration Protocol (GARP) or a Multiple Registration Protocol (MRP).

Bridge Configuration

This page controls the bridging function and classification of tagged Ethernet frames into priority queues. Q0 is the lowest priority queue.

Layer 2 Control Protocol Frames

Protocol	Bridge	GARP
L2CP Queue Mapping	Q0	Q0

Tagged Ethernet Frames

VLAN Priority	P0	P1	P2	P3	P4	P5	P6	P7	Untagged
VLAN Priority Queue Mapping	Q1	Q0	Q2	Q3	Q4	Q5	Q6	Q7	Q1

Set Default 802.1Q Priority Mappings

Submit Updated Values

Reset Form

PTP800 Sync Solution



- **Successfully tested with Brilliant for 1588 v2 support.**
 - PTP800 wireless Backhaul + Brilliant's Cern2000 (Grandmaster) + BT-750 (Client) solution.

2.1.3 95% Network Load

2.1.3.1 TIE

Systemwide Time-Minute Analysis
Please describe in units of time: Tx=00:4 min; Freq=000000 Hz; 0/180/0/0 0/30/40/0; 0/180/0/0 0/40/41/0;
PTP800: Load: 95%, 21.2.2, PTP: 000, 900, 00:30:000, 200, 0/0/0/0/0/0; Scale: 1.0; Unit: 0.01; 100.000 Data/Min; 11.1.0.2

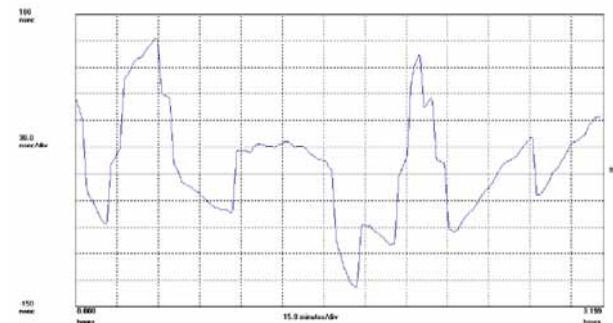

2.1.3.2 MTIE

Systemwide Time-Minute Analysis
Please describe in units of time: Tx=00:4 min; Freq=000000 Hz; 0/180/0/0 0/30/40/0; 0/180/0/0 0/40/41/0;
PTP800: Load: 95%, 21.2.2, PTP: 000, 900, 00:30:000, 200, 0/0/0/0/0/0; Scale: 1.0; Unit: 0.01; 100.000 Data/Min; 11.1.0.2

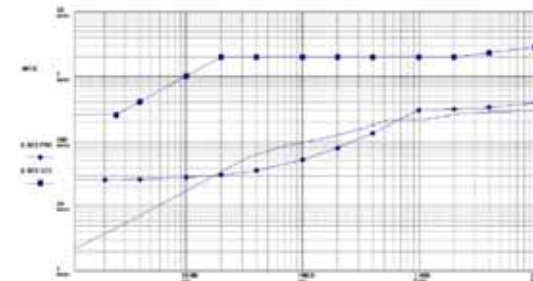

- **PTP800 is hardware ready, software support in future for:**
 - ITU-T G.8262 SyncE
 - Transparent Clock for IEEE 1588 v2

PTP800 - Ethernet Private Line Service



- PTP 800 provides single EPL service.
- Emulates a wired Ethernet connection
 - Compatible with all standard Ethernet frame types
- No routing (layer 3) features
- Jumbo frames up to 9600 bytes
- MEF 9 Certification in Q3 2010.

Flexible Network Management



- Motorola One Point Wireless Suite
- Remote management via Web browser
- Integrate with existing network management systems:
 - Industry standard SNMP v1 and v2c
 - Both private MIB and enterprise MIB:
 - MIB-II, RFC-1213
 - Bridge MIB, RFC-1493
 - RFC-2233 MIB
 - PTP proprietary MIB

Motorola One Point Wireless Suite



Design
Deploy

BroadbandPlanner

PTP LINKPlanner

LANPlanner

Wireless Manager

RFMS

AirDefense



Manage
Secure



One Point Wireless Suite

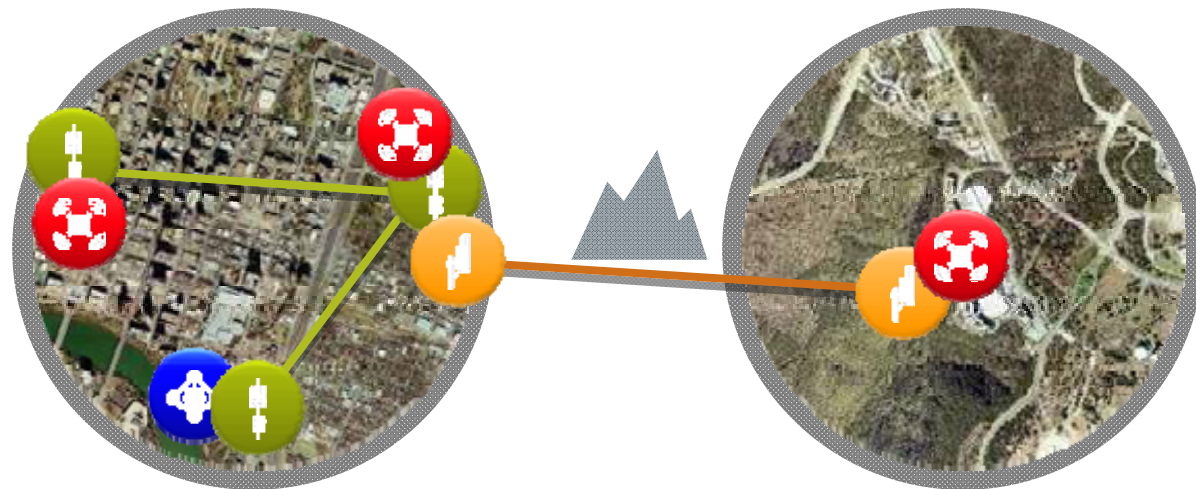
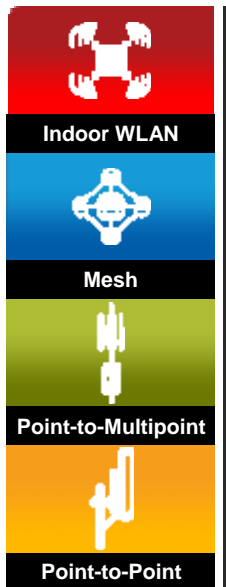

PTP LINKPlanner



- Perform calculations for licensed and unlicensed PTP products
- Plan and optimize a single link or multiple links simultaneously
- Accurately predict PTP link performance and set realistic expectations
- See an overview of the entire wireless network via Google™ Earth
- Obtain a complete licensed-microwave Bill-of-Materials (BOM)

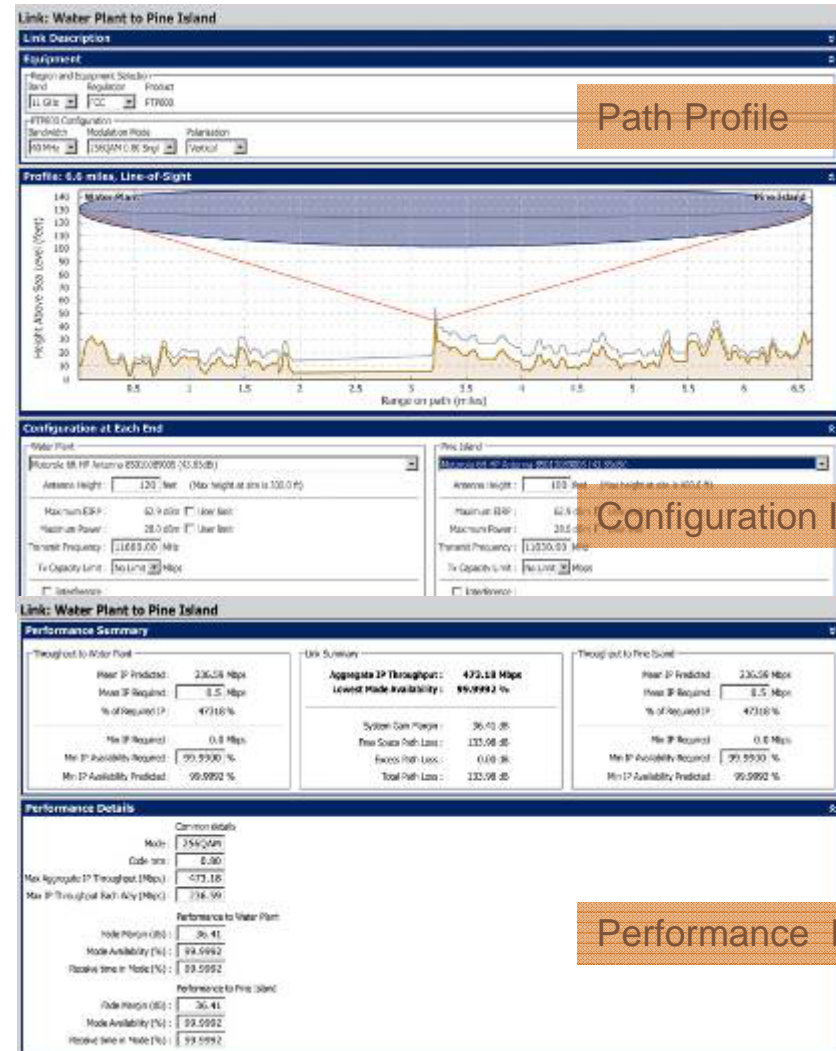



Redundant Configuration

2+0 & 1+1

Configurations



Configuration	CMU/ODU Pairs	Tx Freq Pair (Lo/Hi)	Capacity	Redundancy
1+0	1	1	1	No
1+1	2	1	1	Full H/W redundancy
2+0	2	2	2	Full H/W redundancy, half capacity during H/W failure

Direct Mount



1+0



1+1



1+1 Setup

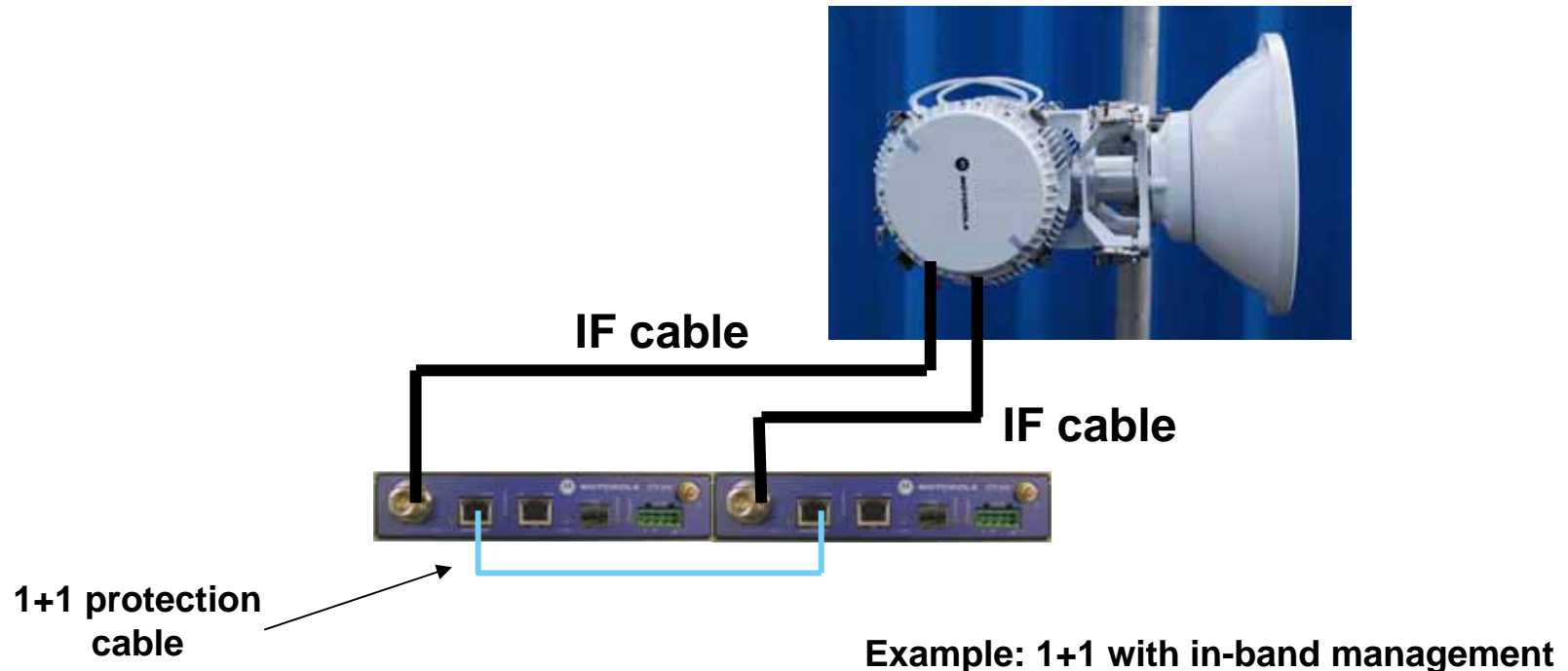

- On each link end, there are two CMU/ODUs. One CMU is “Primary” and the other is “Secondary”.
- PTP800 1+1 support antenna redundancy when CMU/ODU connected to different antennas. When Antenna is shared, a coupler is required to direct mount two ODUs with antenna.
- Each CMU has its own IP address, all CMU are accessible.
- A protection kit may required for a 1+1 configuration when use Out-of-band management.
- A Fiber Y-cable kit may required for a 1+1 configuration when use Optical-Y configuration
- Capacity license can not propagate in 1+1 configuration. Each CMU has its own capacity license.
- To support AES encryption, all four CMUs need have AES enabled.

How 1+1 works ?

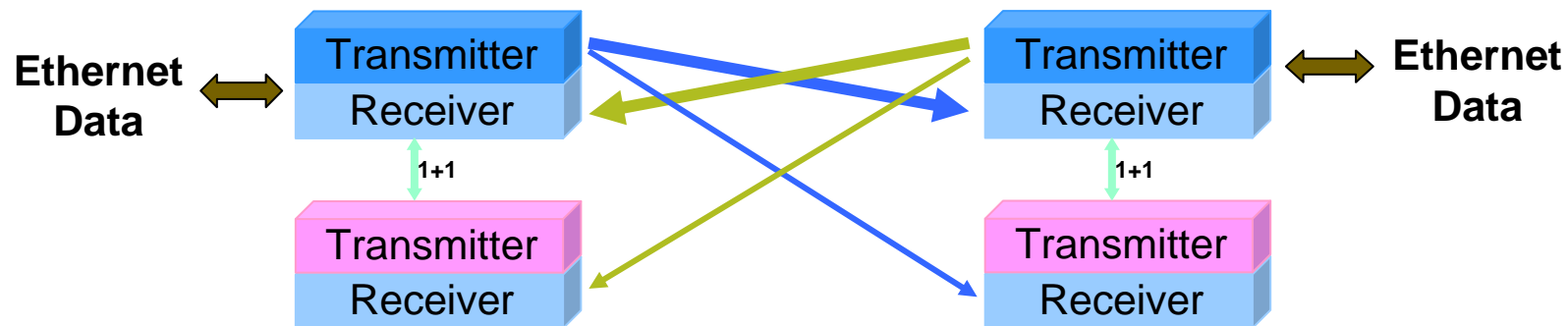

- At any given time, only one CMU/ODU pair at each side can be “Active” and the other CMU/ODU pair must stay “Inactive”.
 - The “Active” CMU/ODU transmits and receives data over the air, forward and receive Ethernet data frames with user equipment.
 - The “Inactive” CMU/ODU receives data over the air and de-modulate the MAC-MAC message, but no transmitting over the air or forwarding the Ethernet data to user equipment.
- The two Ends of the link can switch independently
- 50 ms switch time *
- During failover, some packet losses could happen on both directions.

* The switch time depends on modulation, coding modes and trigger of the switch. In certain circumstance, the radio switch time could be between 50 - 250 ms.

Failure Case

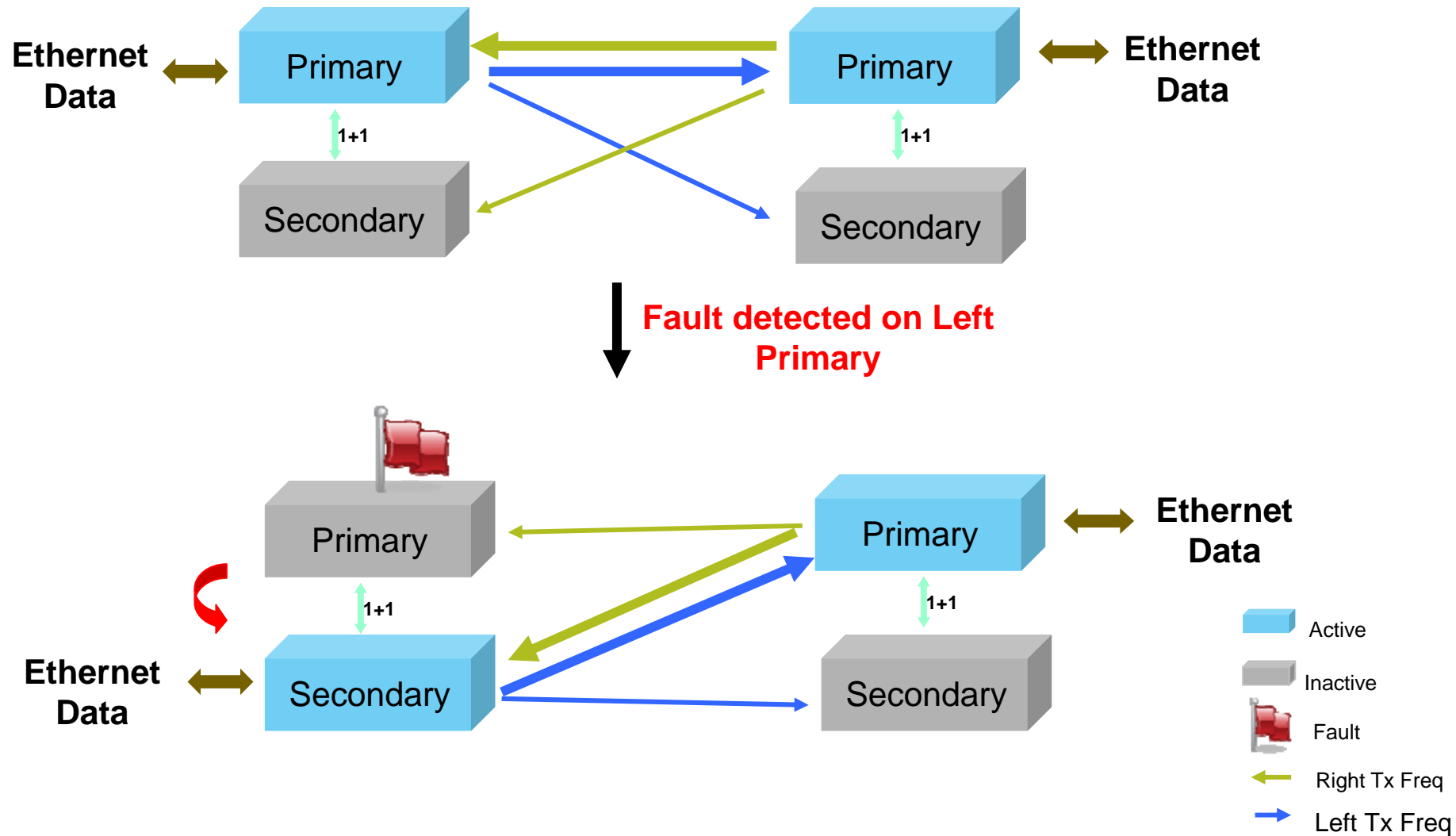

1+1 Inband with Redundant Copper

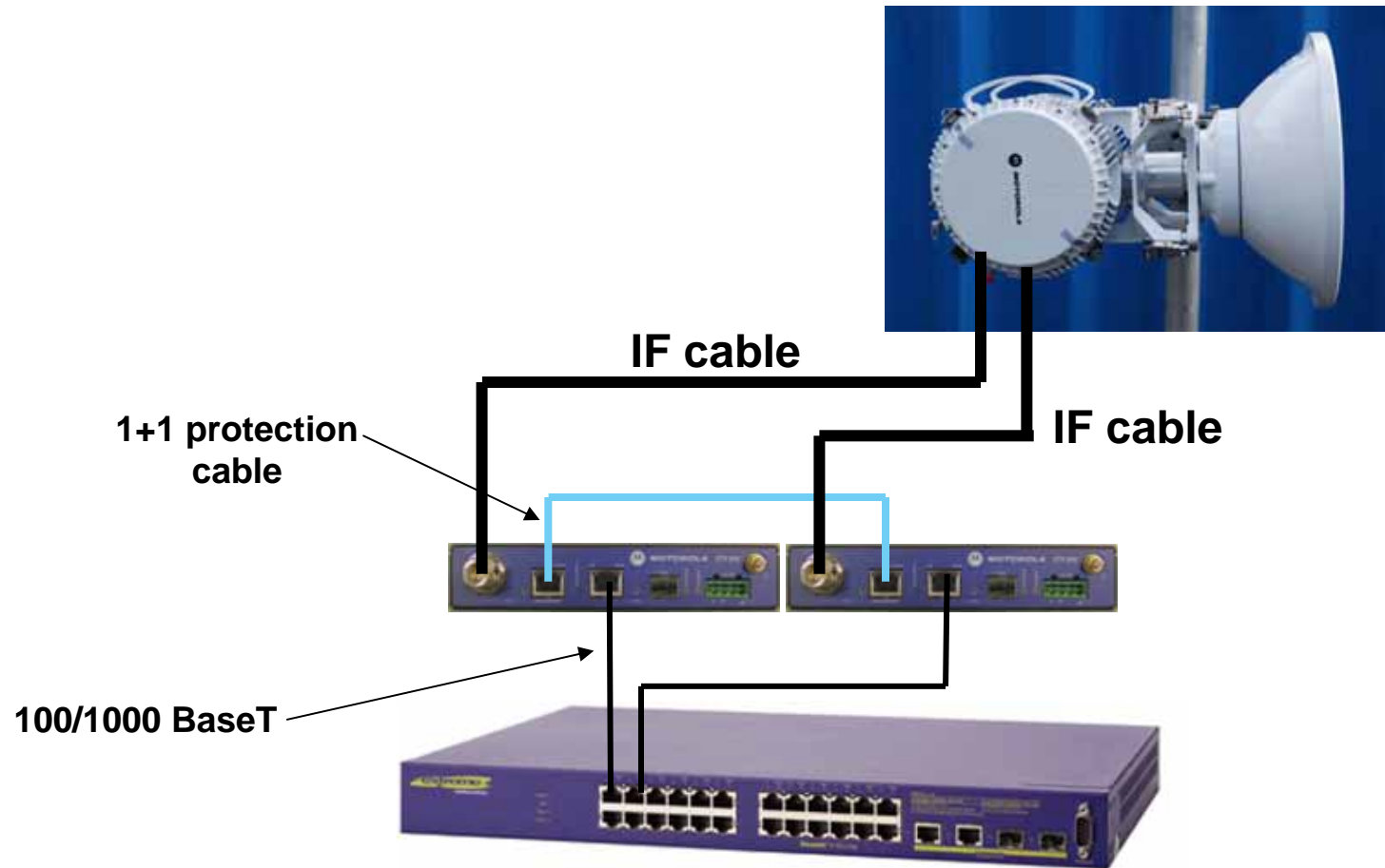

1+1 Inband with Redundant Fiber

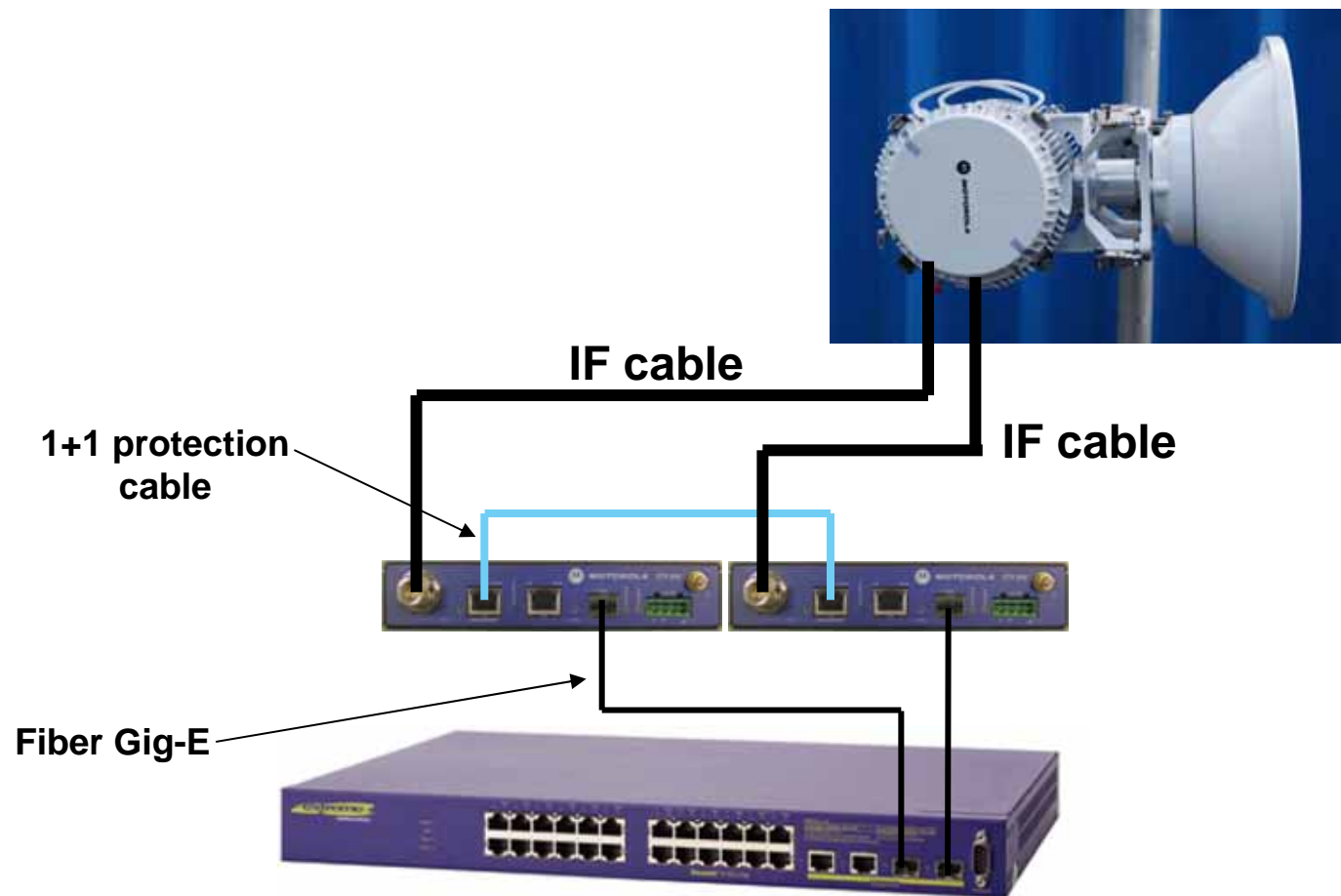

1+1, Out of Band with Redundant Copper

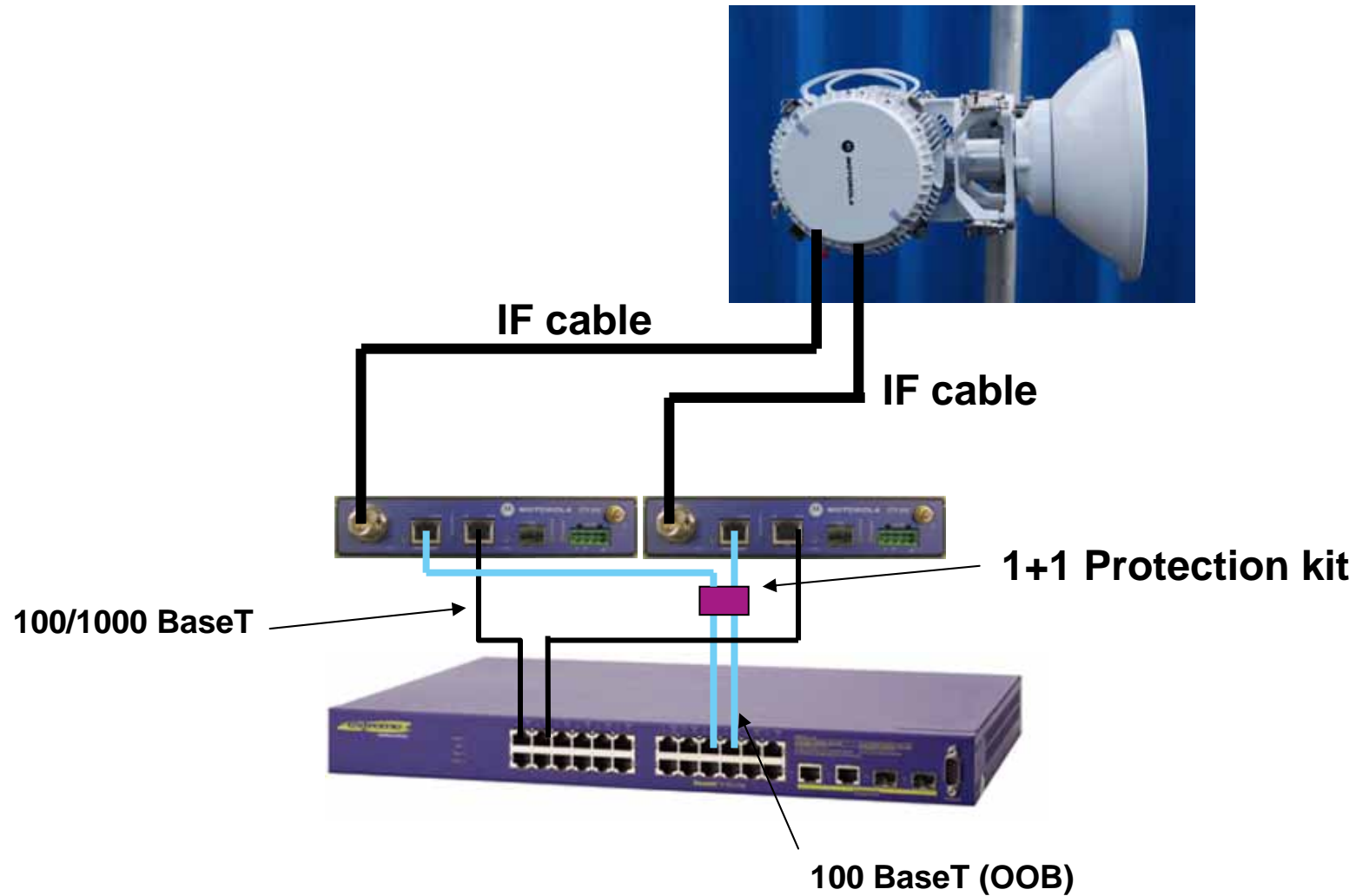

1+1, Out of Band with Redundant Fiber

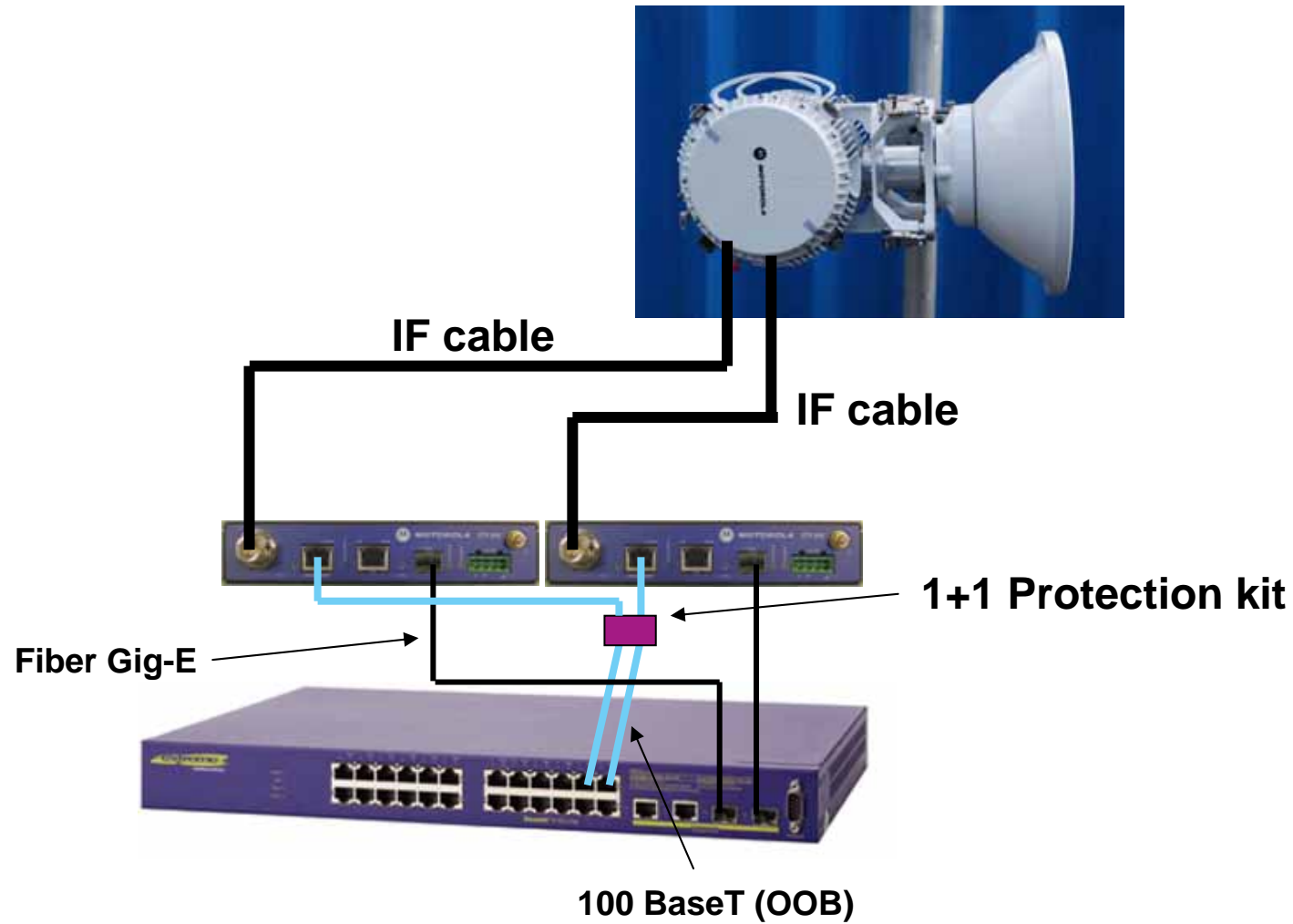

1+1, Out of Band with Optical-Y

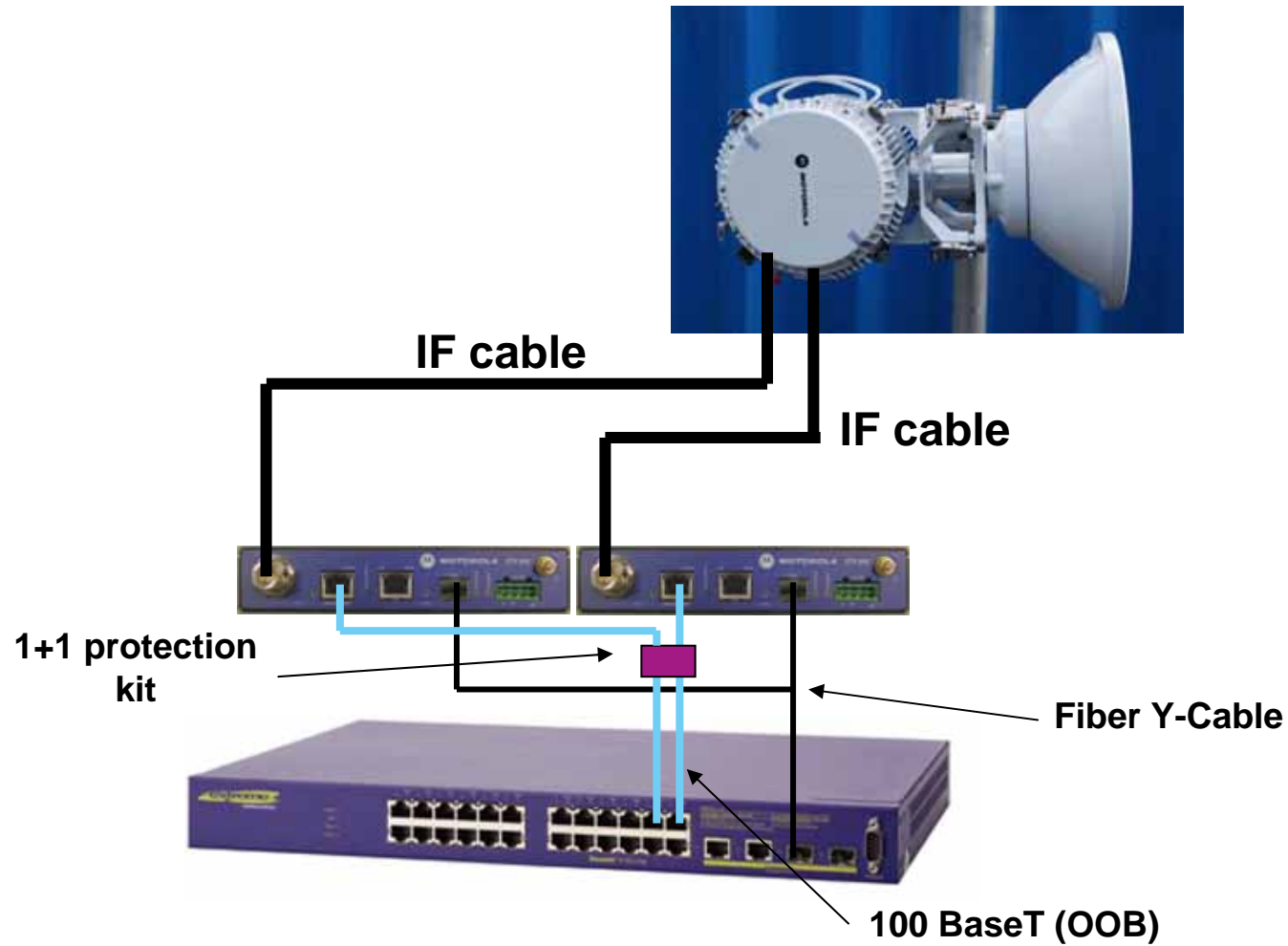

Optical-Y vs. Redundant Copper/Fiber



Total Outage Time

- PTP 800 switch over time + Network Equipment switch over time
- 50 ms PTP800 switch time
 - The switch time depends on modulation, coding modes and trigger of the switch. In certain circumstance, the radio switch time could be between 50 - 250 ms.
- **Optical-Y:**
 - Data path is a single Fiber connection to the Network Equipment
 - No outage attributed to Network Equipment.
 - Total outage time depends solely on PTP 800 delays
 - A disadvantage of Optical-Y is that it can only be managed with Out-of-Band management ports. This is because the optical device in the Inactive CMU has transmission disabled.
- **Redundant Copper/Fiber:**
 - Outage time associated with the Ethernet Switch is significant as it relies on the Ethernet Switch flushing its forwarding database in order to learn the route of the new path
 - Measurements indicate that this can vary between different Ethernet Switches with outages in the order of a few hundred milliseconds.
 - Unlike Optical-Y, configurations with redundant data paths can support in-band management.

Upgrading for 1+0 to 1+1



- **All equipments are re-useable.**
- **Additional hardware required when upgrading**
 - 2 x CMU's + 2 x ODU's
 - 2 x IF cables + 2 x Cable assembly kit + 2 x LPU kit
 - 1 x PTP 800 1+1 protection cable kit
 - 2 x Couplers when antenna is shared, or 2 x Antenna when each ODU has its own antenna.
 - Managed Layer 2 Ethernet switch may be required. Depends on the configuration a customer wants to deploy.

2+0 Configuration



- Requires 2 x frequency pairs

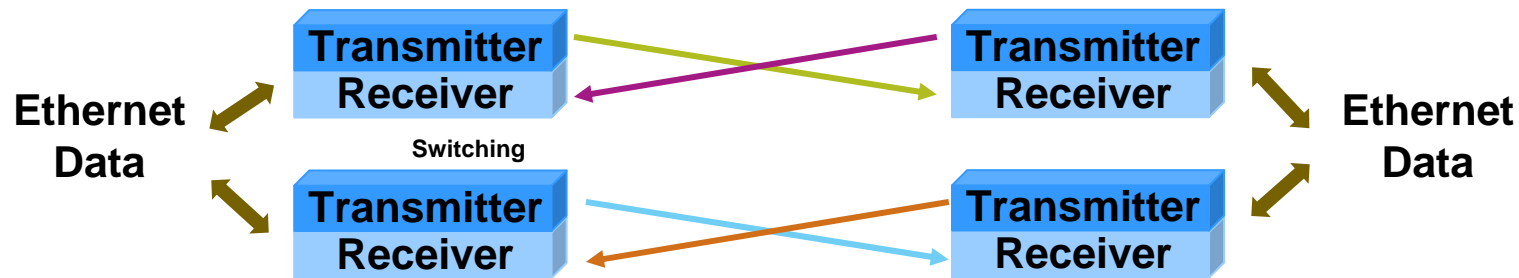

- Capable of 2 X 368 Mbps (736Mbps) using 2 radios in 2 separate channels

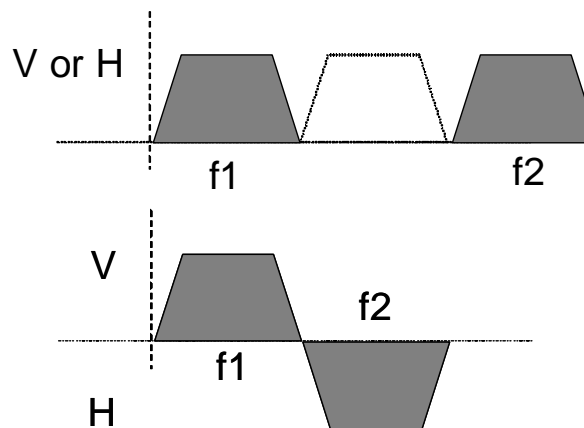

2+0 setup

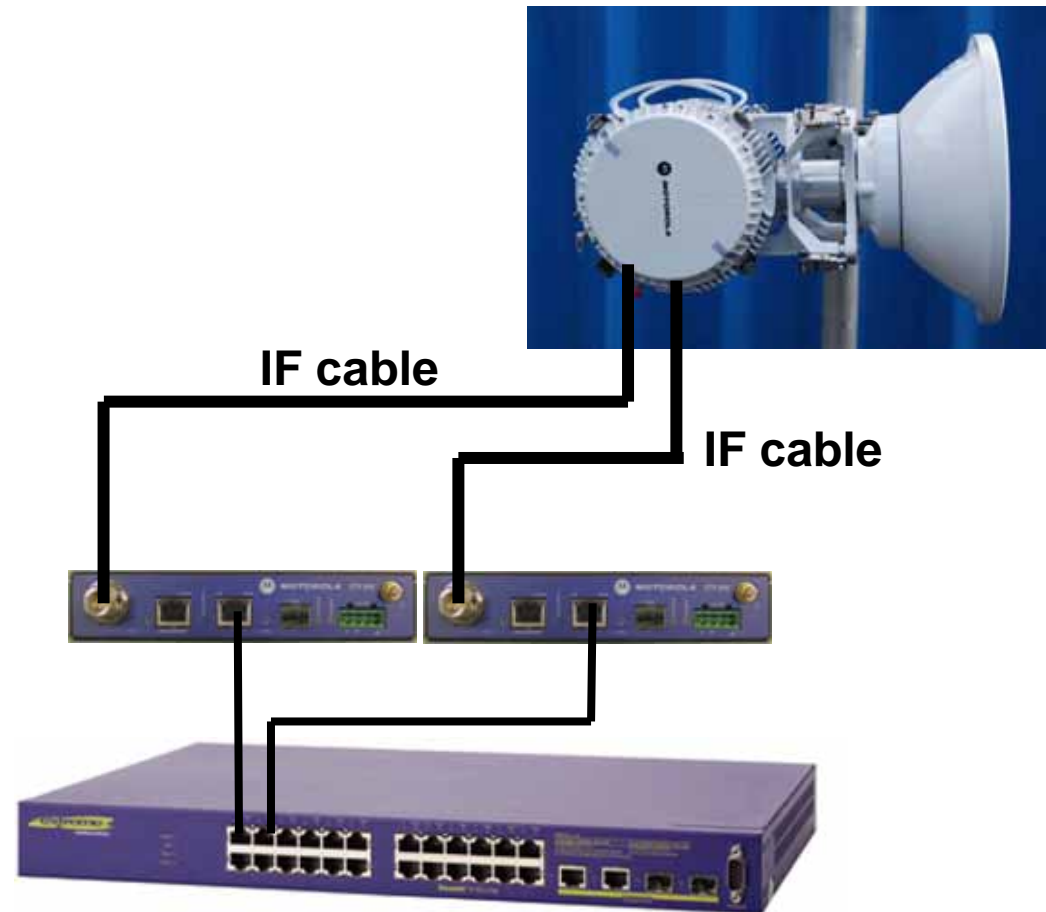

Upgrading for 1+0 to 2+0



- **All equipments are re-usable**
- **If Couplers are being considered, the link profile should be recalculated to ensure that the additional losses still meet availability requirements**
- **Additional hardware required when upgrading**
 - 2 x CMU's + 2 x ODU's
 - 2 x IF cables + 2 x Cable assembly kit + 2 x LPU kit
 - 2 x Couplers when antenna is shared, or 2 x Antenna when each ODU has its own antenna.
 - Managed Layer 2 Ethernet switch

Summary



- 1+0 and 2+0 are supported today, 1+1 HSB will be supported in PTP 800-03-00 release, plan to release by Q4, 2010.
- 1+1 provides full hardware redundancy with single frequency pair required.
- 2+0 provides full hardware redundancy with two frequency pairs required, but it support 2 x capacity. During hardware failure, the capacity will be reduce by half.
- To upgrade from 1+0 to 1+1 or 2+0 configuration, all existing equipments are re-useable.



PTP Competitive Advantage

PTP 800 Key Advantages

technology



MOTOROLA PTP 800	OTHER BRANDS
<p>Complete Ethernet PTP portfolio – with both licensed and unlicensed solutions, Motorola provide complete licensed and unlicensed, LOS and NLOS RF solutions. Customers can mix and match solutions to meet virtually any business, budget and environmental needs</p>	<p>Fewer customer options – less flexibility and higher costs to handle challenging and diverse business, budget and path requirements</p>
<p>Capacity As You Grow – purchase only what you need today and upgrade as needs grow</p>	<p>Less scalability and flexibility – typically fewer options and less convenience</p>
<p>Small form factor – The smallest Modem within industry and is the only Modem hard coated without FAN.</p>	<p>Larger form factors – take up valuable rack space</p>
<p>Errorless & Hitless Adaptive Modulation – provide flexibility and the best possible throughput and highest availability for the radio path without service interruption</p>	<p>Modulation Adjustments – typically need several seconds to adjust the modulation mode, causing outages of several seconds during switchover</p>

PTP 800 Key Advantages

Easy Design, Order, Licensing, Installation & Operation



MOTOROLA PTP 800	OTHER VENDORS
<p>PTP LINKPlanner:</p> <ul style="list-style-type: none">• Optimize both licensed and unlicensed links• Accurately projects performance prior to purchase with terrain profiles, rain fade zone and other environmental factors• Compiles a complete Bill-of-Materials (BOM)• Create single project design profile, accelerate FCC licensing coordination process.• Detailed output for fast deployment	<p>Generic, often unwieldy planning tools:</p> <ul style="list-style-type: none">• Multi-step processes• No environmental factoring• Very basic output• Minimal performance information <p>Complicated configuration process – complex procedures, plus thousands of SKUs make the process time-consuming</p>
<p>Fast, easy installation – PTP LINKPlanner reports, web interface and sophisticated GUI interface speed and simplify deployment; all PTP licensed and unlicensed solutions have the same look and feel</p>	<p>Difficult, error-prone installation procedures – typically using command-line interface</p>

Building sales momentum with PTP800



Summary – Why Motorola?

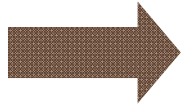

Radio Experience and Expertise

End-to-end solution

Easy to buy, deploy, operate

Global presence

One Point Wireless Suite

Complete Ethernet backhaul portfolio

Technical innovation